



GS50 Sensors

Catalog MSG33-2358/US



ENGINEERING YOUR SUCCESS.

Application

The GS50 speed sensor belongs to the Parker family of accessories provided to complement electronic control systems. The GS50 is a digital output, non-contact, ferrous sensor and has a wide voltage supply range for mobile hydraulic applications. The GS50 can be used as a speed pickup with a variety of toothed wheels. The sensor has twelve inch leads with an attached Deutsch connector. To make the sensor suitable for mobile equipment, we have focused upon properties such as reliability and ease of installation.

Properties

Reliability

The GS50 has a glass-filled nylon plastic construction for sturdiness and corrosion resistance. The mounting hole is reinforced with an aluminum insert for added strength. The sensor uses back-biased, Hall-effect technology for trouble free operation. The GS50 has a self-adjusting digital output which is immune to variations in air gap and rotary alignment. The sensor is very robust and able to withstand rugged applications.

Installation

The GS50 is well designed for the mobile hydraulics industry. The sensor barrel has an o-ring seal. The 3 pin connector is a sealed Deutsch DTM type designed for automotive use. This connector combined with potted electronics gives the sensor IP67 protection for exposed outdoor applications. The single mounting hole in the flange simplifies alignment. These features provide for easy installation and removal, even in field conditions.

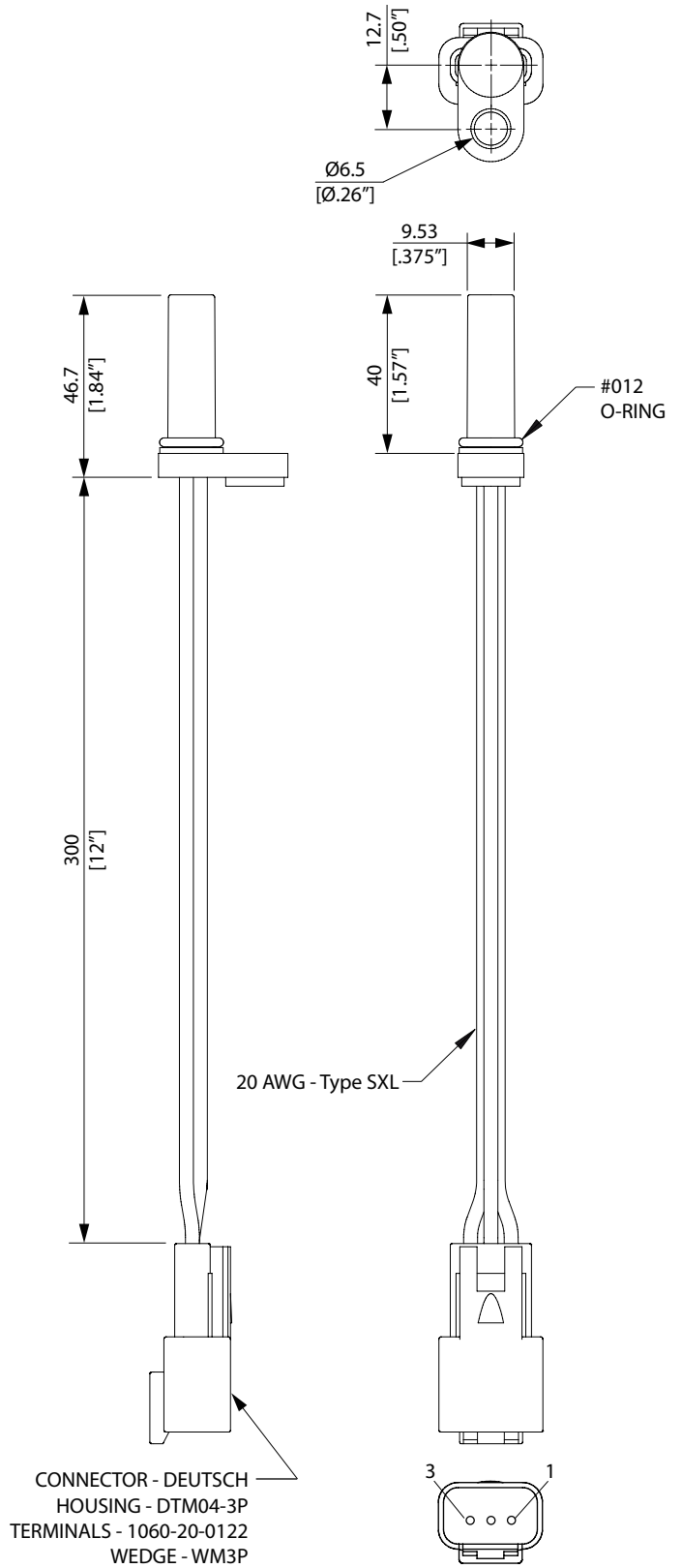

General

Weight 23 g
 Temperature range -20°C to 125°C
 Air gap 0 - 3 [0 - .12"]
 (target size and material dependent)

Mechanical characteristics

Mounting Flange
 Connector Deutsch DTM

Electrical specifications

Frequency range 0 - 15 kHz
 Supply Voltage(Vs) 5 - 16 Vdc operational
 Max 30 Vdc
 Current supply 3 mA typical
 Max 6 mA
 Output type Digital switch,
 open collector¹
 Output current Max 25 mA

Ordering part number

GS50 01711ECD

Environmental protection

ESD

JEDEC 22-A114 HBM 3 kV

Mechanical

Shock 1m drop
 Vibration 30 Gs

Climate

Sealing (electronics) IP67

Chemical environment

Liquids (resistance) standard automotive

1) *Requires external output resistor.
 Refer to installation sheet for more information.*



WARNING - USER RESPONSIBILITY

FAILURE OR IMPROPER SELECTION OR IMPROPER USE OF THE PRODUCTS DESCRIBED HEREIN OR RELATED ITEMS CAN CAUSE DEATH, PERSONAL INJURY AND PROPERTY DAMAGE.

- This document and other information from Parker-Hannifin Corporation, its subsidiaries and authorized distributors provide product or system options for further investigation by users having technical expertise.
- The user, through its own analysis and testing, is solely responsible for making the final selection of the system and components and assuring that all performance, endurance, maintenance, safety and warning requirements of the application are met. The user must analyze all aspects of the application, follow applicable industry standards, and follow the information concerning the product in the current product catalog and in any other materials provided from Parker or its subsidiaries or authorized distributors.
- To the extent that Parker or its subsidiaries or authorized distributors provide component or system options based upon data or specifications provided by the user, the user is responsible for determining that such data and specifications are suitable and sufficient for all applications and reasonably foreseeable uses of the components or systems.

OFFER OF SALE

The items described in this document are hereby offered for sale by Parker-Hannifin Corporation, its subsidiaries or its authorized distributors. This offer and its acceptance are governed by the provisions stated in the detailed "Offer of Sale" available from your Parker representative or at www.parker.com.



WARNING - California Proposition 65

This product can expose you to chemicals including CARBON BLACK (AIRBORNE, UNBOUND PARTICLES OF RESPIRABLE SIZE), NICKEL COMPOUNDS, SILICA, CRYSTALLINE (AIRBORNE PARTICLES OF RESPIRABLE SIZE) (O2SI) which is known to the State of California to cause cancer. For more information go to www.P65Warnings.ca.gov

Parker Motion Systems International Sales Offices

North America

Motion Systems Group Headquarters

6035 Parkland Boulevard
Cleveland, OH 44124-4141 USA
Tel: 216-896-3000
Fax: 216-896-4031

Parker Canada Division

160 Chisholm Drive Milton
Ontario Canada L9T 3G9
Tel: 905-693-3000
Fax: 905-876-1958

Parker Hannifin de México

Industrial Hydraulic Sales
Eje Uno Norte No.100
Parque Industrial Toluca 2000
Toluca, Edo, de Mexico CP 50100
Tel: 52 722 275 4200
Fax: 52 722 279 9308

Parker Hannifin de México

Mobile Hydraulic Sales
Via de FFCC a Matamoros 730
Apodaca, NL, de Mexico CP 66600
Tel: 52 81 8156 6000
Fax: 52 81 8156 6068

Europe

Motion Systems Group Headquarters

La Tuilière 6
1163 Etoy - Switzerland
Tel: 41 21 821 8500
Fax: 41 21 821 8580

South Africa

Parker Hannifin Africa Pty Ltd

P.O. Box 1153
ZA-Kempton Park 1620,
Republic of South Africa
Tel: 27 11 961 0700
Fax: 27 11 392 7213

Mobile Sales

Mobile Sales Organization and Global Sales

850 Arthur Avenue
Elk Grove Village, IL 60007 USA
Tel: 847-258-6200
Fax: 847-258-6299

Industrial Sales

Central Region

1042 Maple Avenue
Unit 331
Lisle, IL 60532 USA
Tel: 630-964-0796

Great Lakes Region

6035 Parkland Boulevard
Cleveland, OH 44124-4141 USA
Tel: 216-896-2740
Fax: 866-498-7507

Gulf Region

20002 Standing Cypress Drive
Spring, TX 77379 USA
Tel: 817-473-4431
Fax: 888-227-9454

Southwest Region

700 S. 4th Avenue
Mansfield, TX 76063 USA
Tel: 817-473-9341
Fax: 817-473-2680

Mid Atlantic and Southeast Regions

1225 Old Alpharetta Road
Suite 290
Alpharetta, GA 30005 USA
Tel: 770-619-9767
Fax: 770-619-9806

Midwest Region

8145 Lewis Road
Minneapolis, MN 55427 USA
Tel: 763-513-3535
Fax: 763-544-3418

Northeast Region

P.O. Box 396
Pine Brook, NJ 07058 USA
Tel: 973-227-2565
Fax: 973-227-2467

Northwest Region

6458 North Basin Avenue
Portland, OR 97217 USA
Tel: 503-283-1020
Fax: 866-611-7308

Pacific Region

8460 Kass Drive
Buena Park, CA 90621
Tel: 714-228-2510
Fax: 714-228-2511

Asia Pacific

Parker Hannifin Shanghai Ltd

280 Yunqiao Road,
Jin Qiao Export Processing Zone
Shanghai 201206, China
Tel: 86 21 2899 5000
Fax: 86 21 6445 9917

Parker Hannifin Hong Kong Ltd

8/F, Kin Yip Plaza
9 Cheung Yee Street
Cheung Sha Wan, Hong Kong
Tel: 852 2428 8008
Fax: 852 2425 6896

Parker Hannifin Korea Ltd

9F KAMCO Yangjae Tower
949-3 Dogok1-dong, Gangnam-gu
Seoul, 135-860, Korea
Tel: 82 2 559 0400
Fax: 82 2 556 8187

Parker Hannifin India Pvt Ltd

Plot No. EL-26, MIDC
TTC Industrial Area
Mahape, Navi Mumbai, 400 709 India
Tel: 91 22 6513 7081
Fax: 91 22 2768 6841

Parker Hannifin Australia

Parker Hannifin Pty Ltd.
9 Carrington Road
Castle Hill, NSW 2154, Australia
Tel: 612 9634 7777
Fax: 612 9842 5111

Latin America

Parker Hannifin Ind. e Com. Ltda Hydraulics Division

Av. FredericoRitter, 1100
94930-000 Cachoeirinha RS, Brazil
Tel: 55 51 3470 6090
Fax: 55 51 3470 9281

Parker Hannifin Argentina S.A.I.C.

Stephenson 2711
1667-Tortuguitas-Malvinas Argentinas
Pcia. de Buenos Aires, Argentina
Tel: 54 3327 44 4129
Fax: 54 3327 44 4199

Pan American Division

7400 NW 19th Street, Suite A
Miami, FL 33126 USA
Tel: 305-470-8800
Fax: 305-470-8808

